

VMS3SPS Disc Brake Caliper for Industrial & Mining

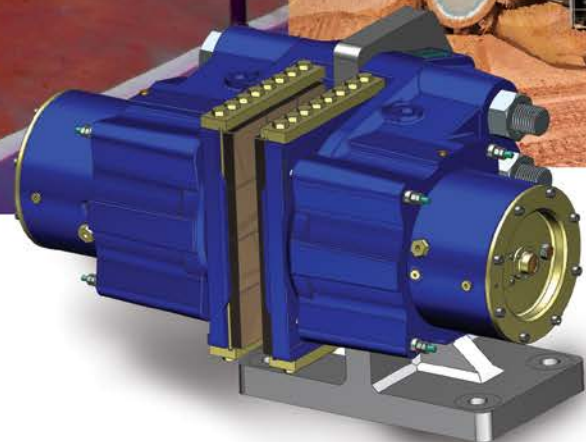

 **Twiflex**[®]
Altra Industrial Motion

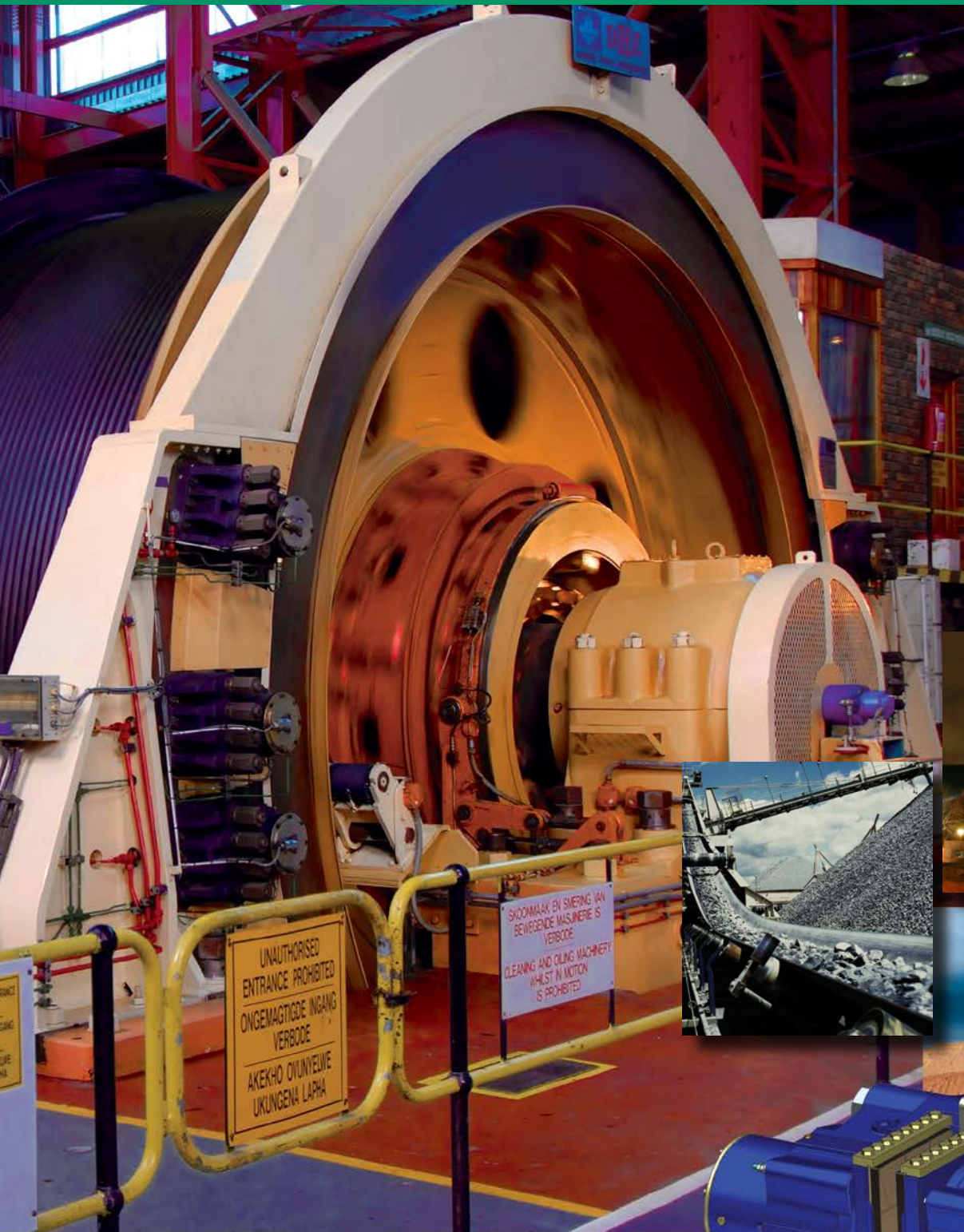

DISTRIBUIDOR MEX (55) 53 63 23 31 MTY (81) 83 54 10 18
AUTORIZADO QRO (442) 1 95 72 60 ventas@industrialmagza.com

VMS3SPS Disc Brake Caliper

Description

With many worldwide installations on mine hoists and based on Twiflex's earlier VMS2SP spring applied, hydraulically released disc brake, the VMS3SPS offers increased braking force in a similar sized package.

The brake comprises two spring modules bolted to a central mounting plate which is 12mm thicker than the brake disc. Minimum disc thickness is 38mm and minimum disc diameter is 1500mm with no maximum except for practical limitations.

The VMS3SPS is fully sealed against moisture and dirt ingress and with the brake in the "parked off" position, disc spring load and hydraulic pressure are zero, allowing pads to be removed in safety. This feature also permits brake installation without the need for hydraulic pressure.

Braking force is a function of both the air gap setting and thickness of the shim pack if fitted.

Fatigue life is > 2 million cycles for most of the models shown at 3mm air gap.

Features

- Weight: 675 kg (2 modules)
- Minimum disc thickness: 38 mm
- Working Fluid: Mineral Oil Based
- Maximum operating pressure: 198 bar
- Pressure port sizes: G1/2 (1/2" BSP)
- Drain port sizes: G1/4 (1/4" BSP)
- Brake pad area (per pad): 107300 mm²
- Swept brake pad path: 289 mm
- Volume displacement per 1mm stroke: 26 ml each module
- Working temperature range: -20°C to 70°C (-40°C optional)
- Pad wear allowance: 11mm
- Min. disc diameter: 1500 mm
- Effective disc radius (Re): Actual radius (m) – 0.155
- Braking Torque (Nm): Braking Force (N) x Re

Floating (Mono Spring) version available
Pedestal / Bracket is optional on request



Scan to View Video
Benefits of the 'Parked Off'
Safety Feature

VMS3SPS

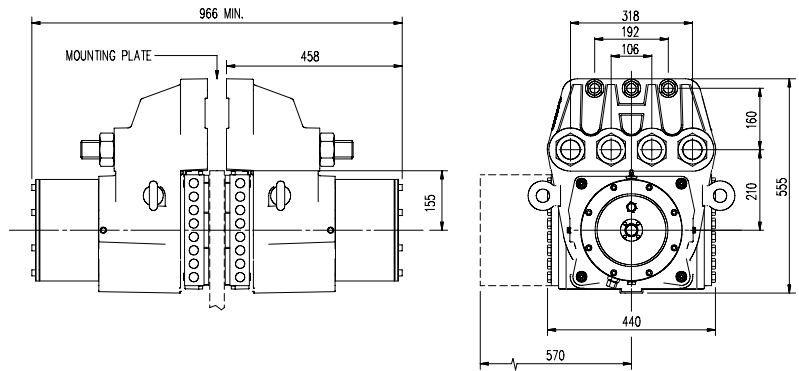

Performance

VMS3 SPS Model	Air Gap (mm)	Braking Force (kN)	Brake Release Pressure (bar)	Full Retraction Pressure (bar)	Specific Pad Pressure (N/mm ²)
SPS 276	3	276	145	158	3.21
SPS 268	3	268	141	154	3.12
SPS 260	3	260	137	149	3.03
SPS 252	3	252	132	145	2.93
SPS 244	3	244	128	141	2.84
SPS 236	3	236	124	137	2.75
SPS 227	3	227	119	132	2.65
SPS 219	3	219	115	128	2.55
SPS 211	3	211	110	124	2.46
SPS 202	3	202	106	119	2.36
SPS 194	3	194	102	115	2.26
SPS 185	3	185	97	110	2.16
SPS 177	3	177	93	106	2.07
SPS 168	3	168	88	101	1.96
SPS 159	3	159	84	96	1.85
SPS 150	3	150	79	91	1.75
SPS 141	3	141	74	87	1.65

Braking forces in the table are at the stated air gap
Braking force increases with a reduction in air gap setting.
Nom. braking force assumes fully bedded in pads, coefficient of friction $\mu = 0.4$