

INFRANOR MAVILOR

BL-190

FEATURES

- High dynamic response.
- Full speed condition, not limited by the "Brush Sparking effect".
- High thermal and dynamic characteristics,
- Very low maintenance

TECHNICAL DATA

CHARACTERISTICS	BLS-190	SYMBOL	UNITS	BL-190	BL-191	BL-192
MAX SPEED		nm	rpm	3500	2800	2800
STALL TORQUE (+/-10%)		Ms	Nm	31	56	82
STALL CURRENT (+/-10%)		Is	A rms	19,71	25.11	34.60
PEAK TORQUE (+/-10%)		Mj	Nm	124	224.0	328
TORQUE-WEIGHT RATIO		Tw	Nm/kg	1.63	1.9	2.1
EMF CONSTANT (+/-5%)		Ke	Vs/rad rms	0.91	1.29	1.37
TORQUE CONSTANT (+/-5%)		Kt	Nm/A rms	1.57	2.23	2.37
RELUCTANCE TORQUE		Tr	Nm	<2%	<2%	<2%
WINDING RESISTANCE (+/-5%)		R	Ω	0.44	0.39	0.26
WINDING INDUCTANCE (+/-5%)		L	mH	2.20	1.9	1.5
ROTOR INERTIA		J	kgm ² 10 ⁻³	5.1	14.7	22
MECHANICAL TIME CONSTANT		Tm	ms	1.57	1.99	1.76
ELECTRICAL TIME CONSTANT		Te	ms	5.01	4.87	5.77
MASS		M	kg	19	29.5	39
N° OF POLES				12	12	12
INSULATION				CLASS-F	CLASS-F	CLASS-F
PROTECTION				IP-65	IP-65	IP-65

MECHANICAL DIMENSIONS

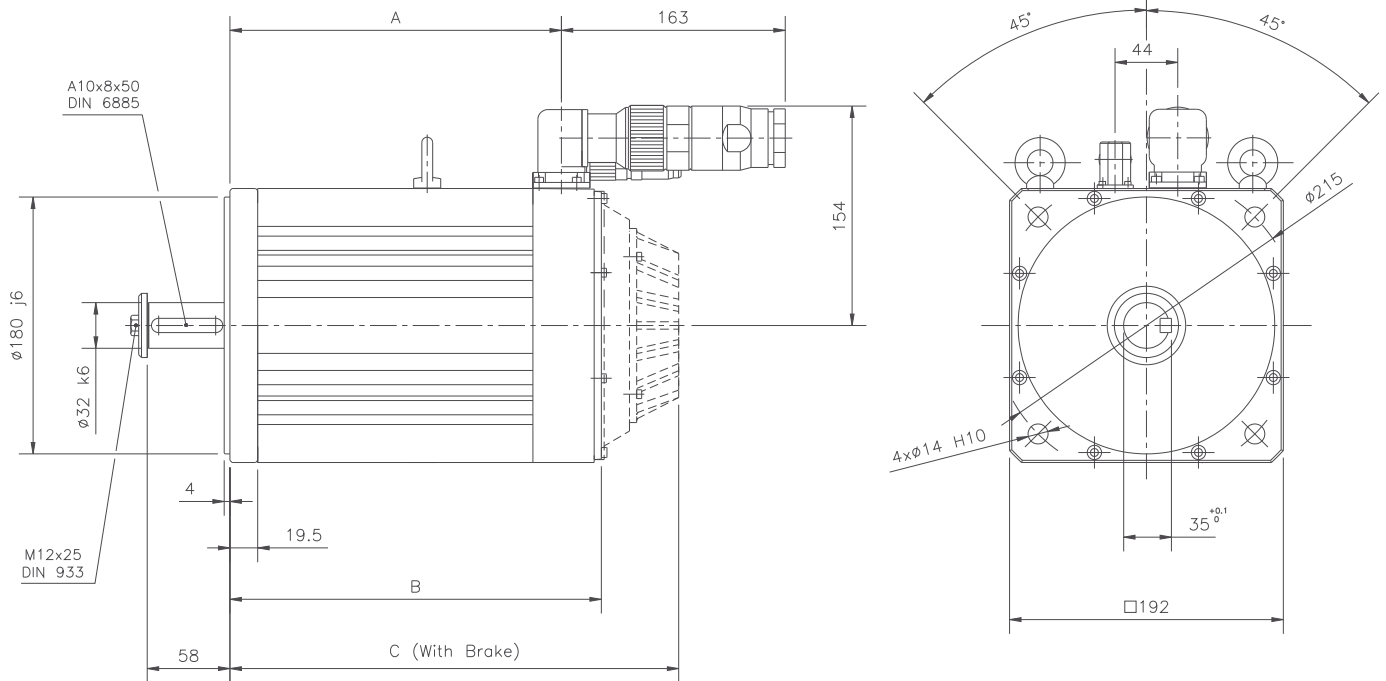

MODELS	A	B	C
BL-190	175.5	203.5	258
BL-191	232.5	260.5	315
BL-192	289.5	317.5	372

TORQUE CURVES

BL-190

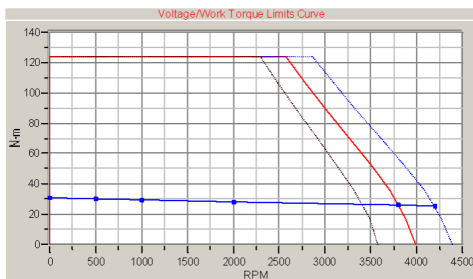

Plot 1: Limit +10% Input voltage. -----
 Plot 2: Limit Nominal Input voltage. -----
 Plot 3: Limit -10% Input voltage. -----
 Plot 4: Limit Continuous Operation. —■—

BL-191

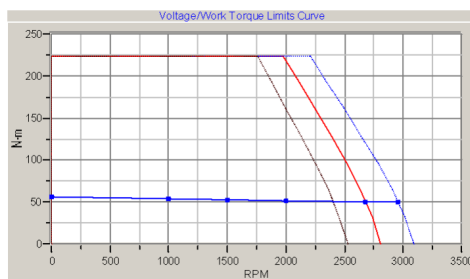

BL-192

